

Quality tester PB-Q^{ONE}

Function

The **PB-Q^{ONE}** is the tool for the detection of the physical and logical communication quality of the data transfer in PROFIBUS networks. With the provided adapter a widely non-reactive connection to the PROFIBUS network is allowed. In this way, the analysis of the communication quality is possible online - during operation of the plant. Through special software all measurement and test results can be displayed and recorded on a computer. The software is easy to use and clearly arranged. A simple menu structure allows to switch between diagnostics and expert modus.

Physical quality analysis

Signal quality

PROFIBUS is based on voltage difference signal which transfers the logical telegram content to the wires A and B. The level of the voltage difference as well as the shape of these signals are indicators of the physical transmission quality respectively the signal quality. Every Bit is scanned 16-times. The evaluation is based on 8/16 of the overall width. Therefore, the signal transition and the transient effect are excluded from the evaluation. As a result a bar chart diagram with a quality value for each analysed device in the network is displayed.

Signal/noise ratio

The signal-to-noise ratio describes the smallest distance between a logical "0" and a logical "1". It indicates to which extend the signal of a device is influenced by external disturbances or signal fluctuation. On the basis of the signal-to-noise ratio sporadic occurring physical failures can be detected.

Logical quality analysis

Device details

In the illustration of the device details all bus devices are displayed in a hierarchic structure including address and detailed diagnosis information. The colouring of the individual devices (green, yellow, red) allows to immediately evaluate the state of each device. Additionally, to the colour-highlighting the results are shown in clear text with a time stamp.

Telegram mode

Further analysis possibilities are available in the telegram mode. Through a number of filter and trigger options the data traffic can be evaluated based on events or defined data content.

Master simulator

An integrated master simulator allows the detection of the real wired bus topology as well as the analysis of the signal quality of the connected bus devices. The master simulator has to be used in the offline-mode without SPS.

Technical data

- PROFIBUS port: 9 pole D-SUB connector
- USB: USB 2.0 port
- Transmission rate: 9,6 kBit/s to 12 MBit/s
- Power supply: 500mA via USB
- Dimension (H x W x D): 60 x 117 x 35 mm
- Type of Protection: IP20
- Operating temperature: 0 °C to +50 °C
- Storage temperature: -20 °C to +70 °C
- Conformity: CE



PB-Q^{ONE}



Quality values

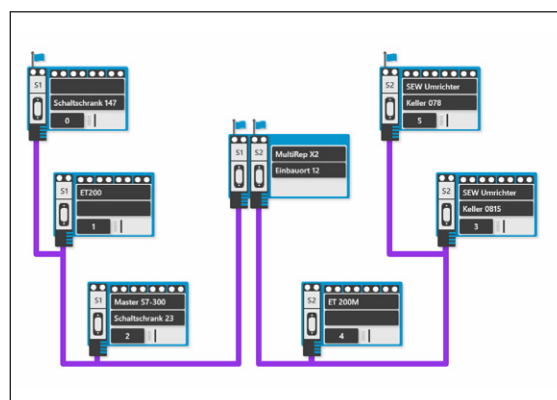

Topology

Ordering details	Art. No.
PB-Q ^{ONE}	110010050
Accessories	
M12 Y-Measuring adapter	110020018
Adapter set M12	110020015